

General Wiring Diagram

Wiring Sample

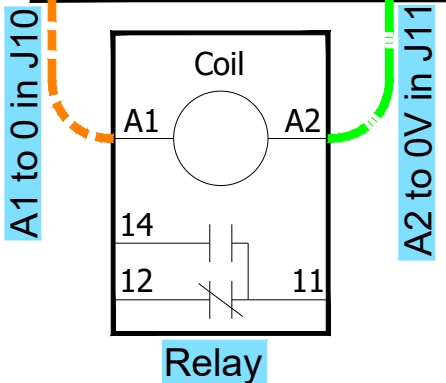

- Relay Pins**
- 11 - Power In
 - 12 - Power Out when Relay Off
 - 14 - Power Out when Relay On

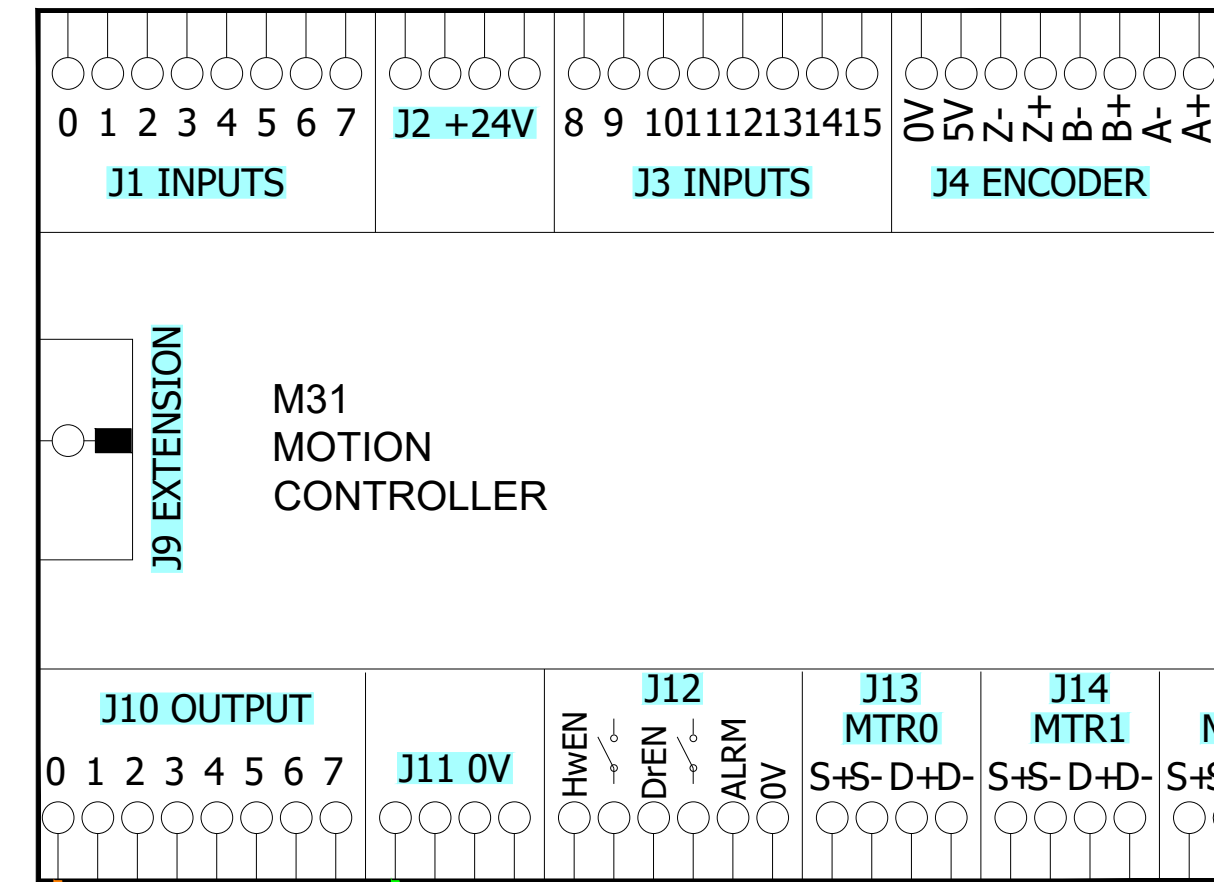
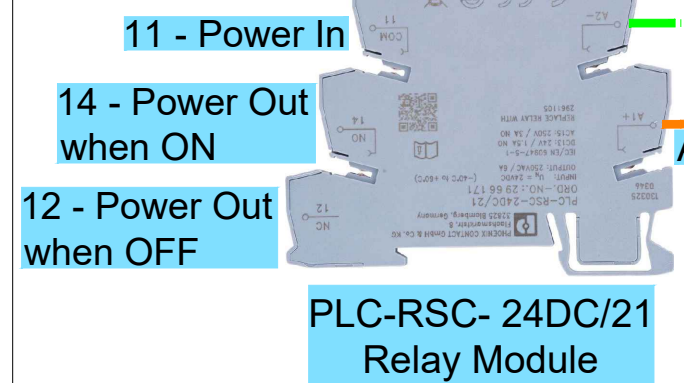
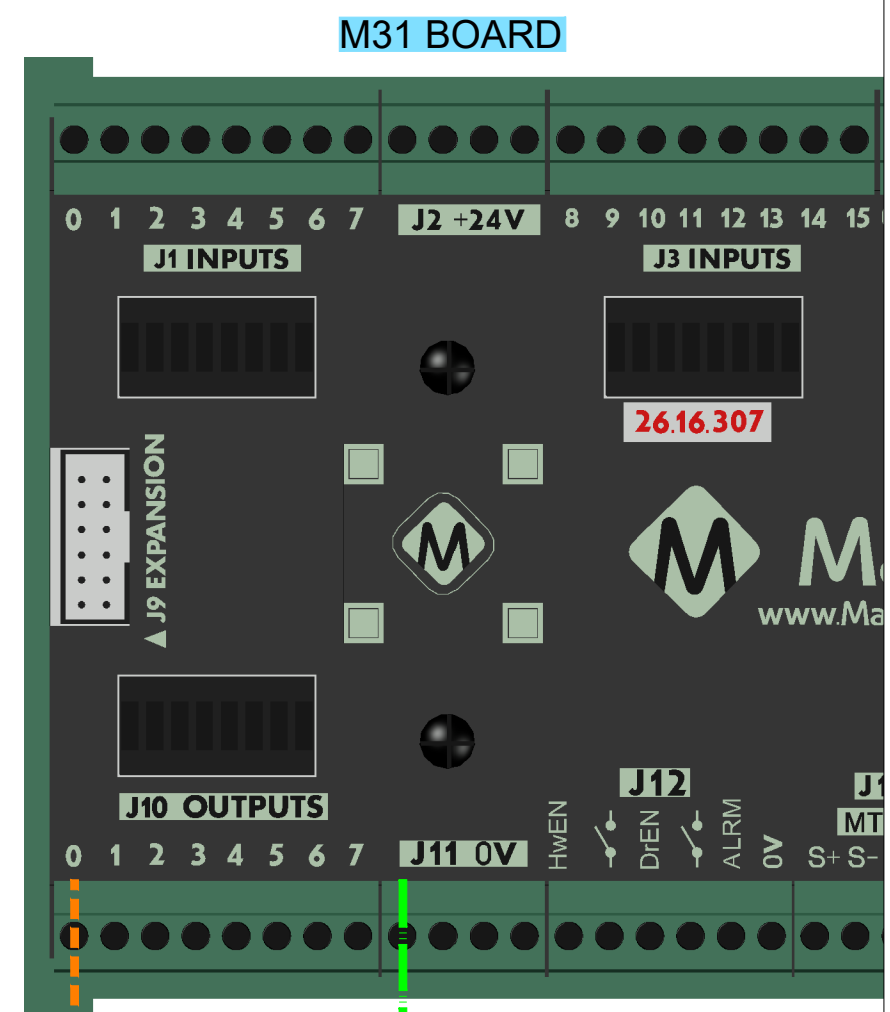

MachLabs														
<small>USA - 14518 County Road 7240 Newburg, MO 65550 sales@mach-labs.com</small>														
Date	07/17/2026	Developed by:	A.VALIEV	Checked by:	P.STEPHENS	Approved by:	C.ELDRIDGE							
A.	Project	Phase	Doc. type	Progr.	Rev.									
M	0	0	0	0	3	K	C	S	D	0	0	1	A	0
M31 to Relay Module														
Wiring Diagram														
General Layout														
<small>CAD file No. M-00003-K-CSD-001-A0</small>														
<small>Page 1 / 1</small>														