

Detail B

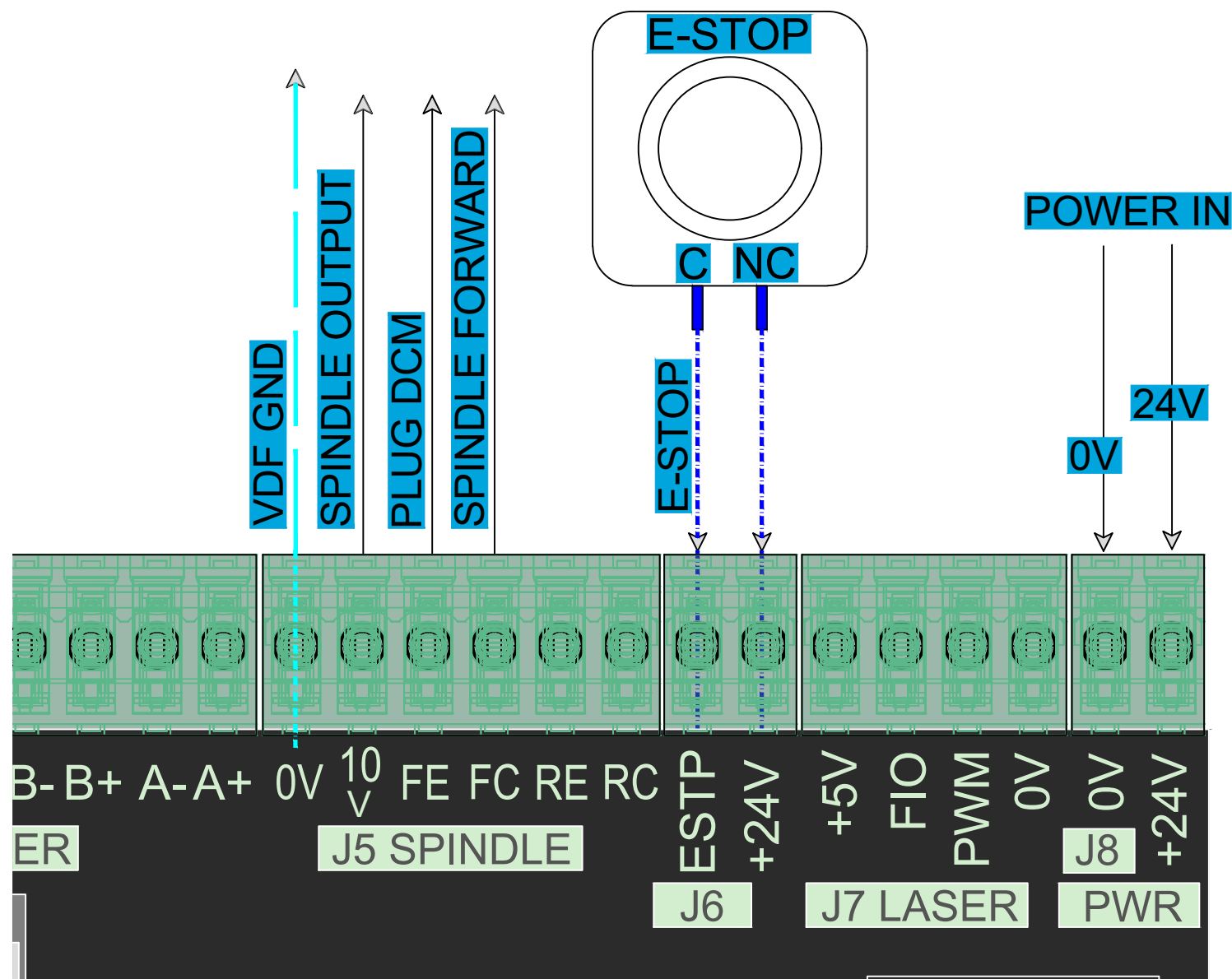

Note:

- E-STOP is controlled through M31 board.
- Keep existing power supply wires on Gecko terminals 11 and 12.
- Remove wires from G540 and connect to pins of M31 as shown in Table below.

Location of the wires to be moved	
Old Location in G540	New Location in M31
Main pinout #7	0V in J5 SPINDLE
Main pinout #8	FC in J5 SPINDLE
Main pinout #9	10V in J5 SPINDLE

MachLabs
 USA - 14518 County Road 7240
 Newburg, MO 65550
 sales@mach-labs.com

Date	03/20/2026	Developed by	A. VALIEV	Checked by	A. MONING	Approved by	C. ELDREDGE
A.	Project	Phase	Doc. type	Progr.	Rev.		
M	0	0	0	0	1	B	C
						S	D
						0	0
						3	A
							1

M31 TO Gecko G540
Wiring Diagram
Detail B

CAD file No. M-00001-K-CSD-003-A1 Page 3 / 3